

SINGER

885-113

THE SINGER 885-113 MACHINE

Description

The 885-113 machine is designed for application in the trimming and setting of shoulder pads in suits and coats. It is similar to the 1110117 machine except in the following respects:

- a. Modification has been made to provide $2\frac{1}{2}$ SPI as compared to 3 SPI.
- b. Two needle thread tensions are provided.
- c. A special adjustable tension release to compensate for varying material thickness has been incorporated.
- d. Maximum recommended speed is 1100 RPM.

Adjustments

Tension Release Bracket

With no material under the presser foot, the lifting presser foot should raise approximately $1/16$ " when the tension release pin engages the tension release bracket to open the tension discs on Tension "A"- Figure 1.

If adjustment is required, loosen Screw "C"- Figure 2 and move the tension release bracket up or down to make the tension discs open earlier or later.

Needle Thread Tensions

Tension "B"- Figure 1 maintains sufficient control on the needle

FIGURE 1

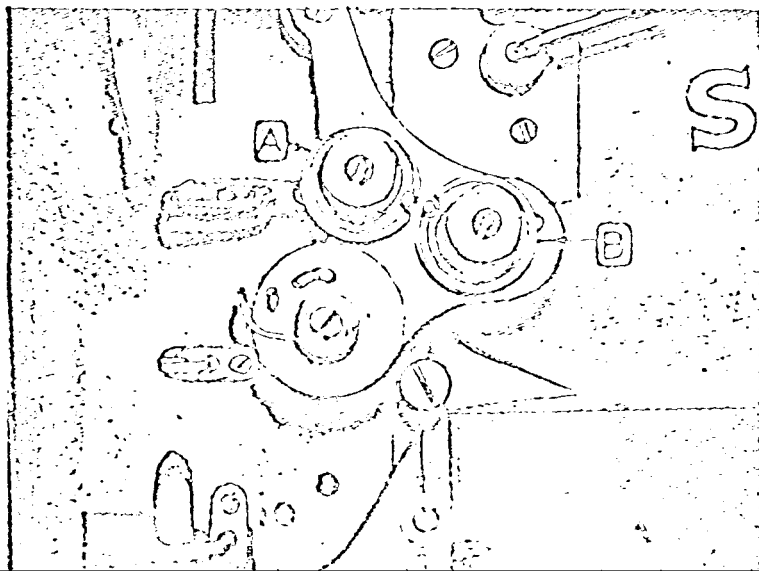
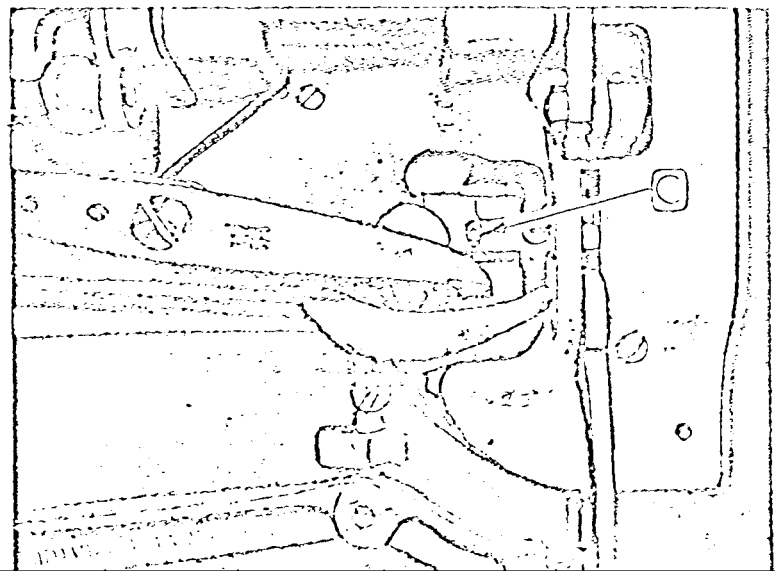

FIGURE 2



THE SINGER 885-113 MACHINE

Single Needle, Lockstitch, Compound Feed, Vertical Trimmer
 (111G117 Converted for 2 1/2 Stitches Per Inch)

126X11

MAXIMUM RECOMMENDED MACHINE SPEED: 1100 RPM. NEEDLE CAT. #4506 #2

Parts List

<i>ALTERED</i>	Tension Complete	223705	
	Tension Release Pin	235576	
	Foot Lifter Lever Spring	227561	
	Needle Bar Rock Frame Crank Pinch Screw	200029	
	Feed Driving Connection Cap Screw	494230-001	
<i>ALTERED</i>	Feed Dog	491716	Specify Gaus
<i>ALTERED</i>	Vibrating Presser Foot	491717	Specify Gaus
<i>ALTERED</i>	Feed Driving Rock Shaft Crank	492065-001	
<i>NEW</i>	Throat Plate Body	492065-002	Specify Gaus
<i>ALTERED</i>	Needle Bar Rock Frame Rock Shaft Crank	492065-003	
<i>NEW</i>	Feed Bar	492065-004	
<i>ALTERED</i>			
<i>NEW</i>	Actuator Finger Insert	492065-007	
<i>ALTERED</i>	Presser Bar Lifting Bracket	492065-006	
<i>ALTERED</i>	Feed Driving Rock Shaft	492065-009	
	Throat Plate Knife Cutting Bar (1/8)	491718008	
	Throat Plate Knife Cutting Bar (5/32)	491718010	
	Throat Plate Knife Cutting Bar (3/16)	491718012	
<i>ALTERED</i>	Throat Plate Knife Cutting Bar (1/4)	491718016	
	Throat Plate Knife Cutting Bar (9/32)	491718018	
	Throat Plate Knife Cutting Bar (5/16)	491718020	
	Throat Plate Knife Cutting Bar (3/8)	491718024	
	Lifting Presser Foot (1/8 & 5/32)	491727008	
	Lifting Presser Foot (3/16)	491727012	
<i>ALTERED</i>	Lifting Presser Foot (1/4)	491727016	
	Lifting Presser Foot (9/32 & 5/16)	491727018	
	Lifting Presser Foot (3/8)	491727024	

From the library of Diamond Needle Corp.

The Singer Company
 Industrial Products Division
 Mechanized Systems Department

Clifton Laboratory
 Clifton, N. J.
 1/18/66

BLACK ... ALTERED in machine - PARTS NOT INTERCHANGEABLE
RED ... REMOVED FROM MACHINE ... ALTERED TO PRINT
BLUE ... NEW PARTS MADE TO PRINT

Adjustments (cont.)

thread while Tension "A"- Figure 1 is released. The setting of this tension is generally very light.

PARTS LIST

<u>Description</u>	<u>Part No.</u>
Tension Complete	223705
Tension Release Pin	235576
Foot Lifter Lever Spring	227561
Needle Bar Rock Frame Crank Pinch Screw	200029
Feed Driving Connection Cap Screw	494230-001
Feed Dog	491716 (Spec. Gauge)
Vibrating Presser Foot	491717 (Spec. Gauge)
Feed Driving Rock Shaft Crank	492065-001
Throat Plate Body	492065-002 (Spec. Gauge)
Needle Bar Rock Frame Rock Shaft Crank	492065-003
Feed Bar	492065-004
Needle Bar Rock Frame Rock Shaft Crank Connection	492065-005
Presser Bar Lifting Bracket	492065-006
Actuator Finger Insert	492065-007
Feed Driving Connection	492065-008
Feed Driving Rock Shaft	492065-009
Throat Plate Knife Cutting Bar (1/8)	491718-003
Throat Plate Knife Cutting Bar (5/32)	491718-010
Throat Plate Knife Cutting Bar (3/16)	491718-012
Throat Plate Knife Cutting Bar (1/4)	491718-016
Throat Plate Knife Cutting Bar (9/32)	491718-018
Throat Plate Knife Cutting Bar (5/16)	491718-020
Throat Plate Knife Cutting Bar (3/8)	491718-024
Lifting Presser Foot (1/8 & 5/32)	491727-003
Lifting Presser Foot (3/16)	491727-012
Lifting Presser Foot (1/4)	491727-016
Lifting Presser Foot (9/32 & 5/16)	491727-018
Lifting Presser Foot (3/8)	491727-024
Needle (#126 x 11)	4506-211

From the library of: Diamond Needle Corp

PART NO.	DESCRIPTION	IN STOCK	MADE FROM SINGER PART	SINGER PART IN STOCK	SINGER PART BACK
223905	TENSION				
235576	" RELEASE PIN				
227561	FOOT LIFTER LEVER SPRING				
200029	SCREW				
494230-001	SCREW				
494997-001	III G117				
492065-001	FEED DRIVE ROCK SHAFT CROWN				
492065-002	THROAT PLATE BODY		240401		
492065-003	N.B. ROCK FRAME CRANK				
492065-006	P.B. LIFTING BRACKET		264526		
492065-007	INSERT				
491717-001	V. PRESSER FOOT $\frac{1}{8}$ " - $\frac{5}{32}$ "		240496		
491717-002	" " " $\frac{3}{16}$ " - $\frac{3}{8}$ "		240497		
491718-008	CUTTING BAR $\frac{1}{8}$ "		240384		
491718-010	" " $\frac{5}{32}$ "		240481		
491718-012	" " $\frac{3}{16}$ "		240483		
491718-016	" " $\frac{1}{4}$ "		240421		
491718-018	" " $\frac{9}{32}$ "		240488		
491718-020	" " $\frac{5}{16}$ "		240490		
491718-024	" " $\frac{3}{8}$ "		240494		
491727-008	L: PRESSER FOOT $\frac{1}{8}$ " - $\frac{5}{32}$ "		240472		
491727-012	" " " $\frac{3}{16}$ "		240473		
491727-016	" " " $\frac{1}{4}$ "		240474		
491727-018	" " " $\frac{9}{32}$ " - $\frac{5}{16}$ "		240475		
491727-024	" " " $\frac{3}{8}$ "		240476		
491716-001	FEED DOG $\frac{1}{8}$ " - $\frac{5}{32}$ "		240456		
491716-002	" " $\frac{3}{16}$ " - $\frac{3}{8}$ "		240457		

REVISIONS

SYM.	DESCRIPTION	CHG'D BY	CHK'D BY	DATE
A	ADDED CHART	W.F.C.		7-21-65
B	ADDED .030 X .025 GROOVE	A.K.S.		8-15-67

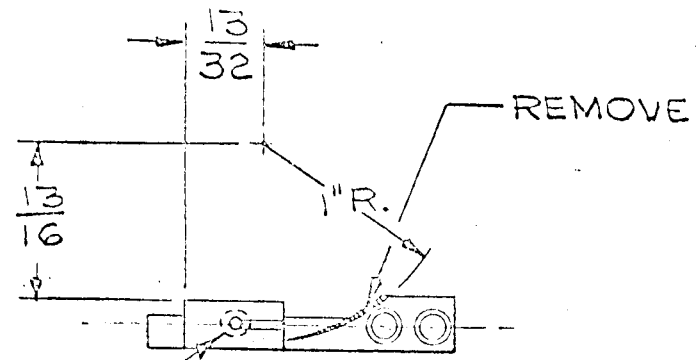

1/16 R. ALL AROUND (OPPOSITE SIDE)

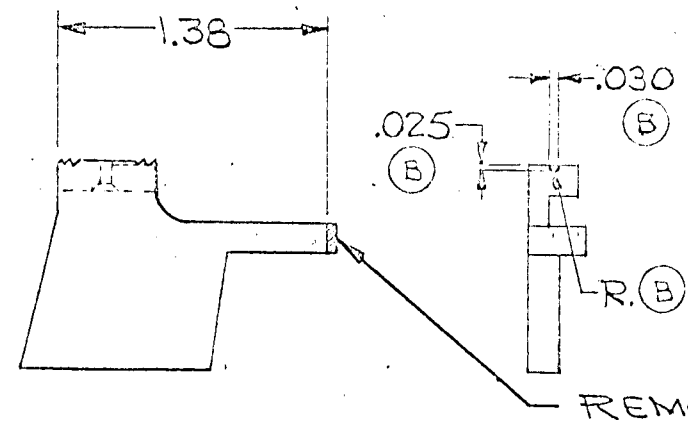

DWG. NO.	MATERIAL	CAGE
491716-001	240456	1/3
491716-002	240457	5/32 TO 2/3

From the library of Diamond Needle Corp

ITEM NO.	REQ'D.	DESCRIPTION	DWG. OR CAT. NO.
----------	--------	-------------	------------------

NAME		FEED DOG , IIIW117			PROJECT NUMBER	
MATERIAL		SEE CHART			THE SINGER COMPANY	
HEAT TREATMENT					INDUSTRIAL PRODUCTS DIVISION	
FINISH					MECHANIZED SYSTEMS DEPARTMENT	
TOLERANCE UNLESS OTHERWISE SPECIFIED					DRAWING NUMBER	
MAL: 2 PLACES ± .010 3 PLACES ± .005		FRACTIONS: ± 1/64			491716	
ANGLES: ±		ALL EDGES BROKEN .005 - .010			DATE OF ISSUE	
					JUL 27 1965	

REVISIONS

SYM.	DESCRIPTION	CHG'D BY	CHK'D BY	DATE
A ₂	REDIMENSIONED; REMOVED .11 FROM R WAS 3/16 APPROX.	N.C.	W.F.C.	10/15/65
B	ADDED CHART & TWO VIEWS WITH DIMS.	W.F.C.		10/15/65
C	CHG'D. MATERIAL TO SEE CHART	W.F.C.		10/15/65

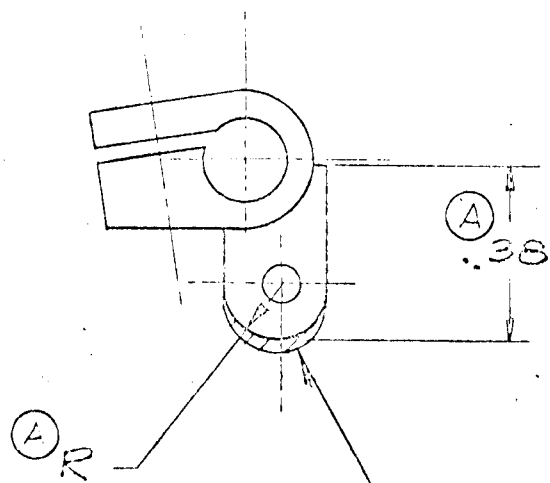

REMOVE SHADED AREA

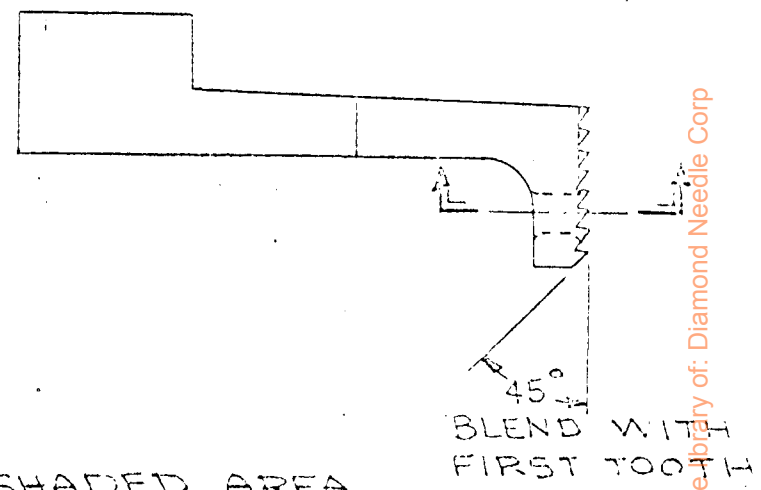

45° BLEND WITH FIRST TOOTH

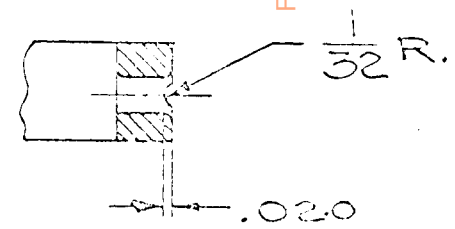

From the Library of: Diamond Needle Corp

DWG. NO.	MATERIAL	GAGA
91717-001	240496	1/8 & 5/32
91717-002	240497	3/16 TO 3/8

ITEM NO.	REQ'D.	DESCRIPTION	DWG. OR CAT. NO.
----------	--------	-------------	------------------

NAME	VIBRATING PRESSER FOOT, IIIW117		
MATERIAL	SEE CHART	DRAWN BY	N.C.
HEAT TREATMENT		DATE DRAWN	7-22-65
FINISH		SCALE	2:1
USED ON		CHECKED BY	W.F.C.
		ENG. APPR.	1/11
		MFG. APPR.	

PROJECT NUMBER
 THE SINGER COMPANY
 INDUSTRIAL PRODUCTS DIVISION
 MECHANIZED SYSTEMS DEPARTMENT
 DRAWING NUMBER

TOLERANCE UNLESS OTHERWISE SPECIFIED
 DIMS: 2 PLACES ± .010
 3 PLACES ± .005
 FRACTIONS: ± 1/64
 ANGLES: ±
 ALL EDGES BROKEN
 .005 - .010

DATE OF ISSUE
 OCT 27 1965

491717

491718

REVISIONS

SYM.	DESCRIPTION	CHK'D BY	CHK'D BY	DATE
A	ADDED TABLE			1/2/65

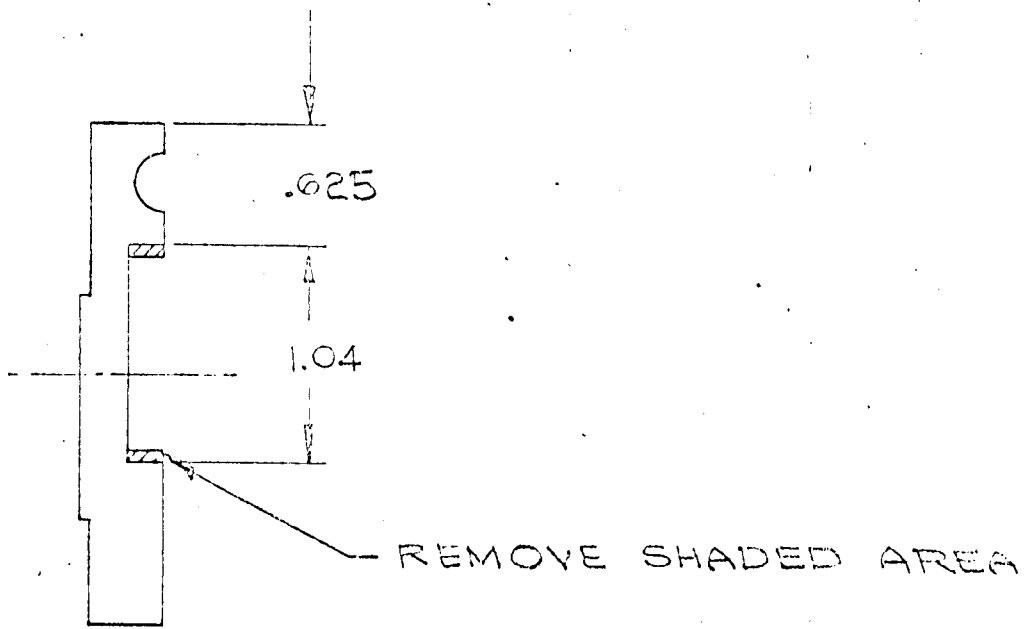

From the library of: Diamond Needle Corp

491718001	1/8	3-10-64
491718000	1/16	3-10-64
491718018	3/32	3-10-65
491718016	1/2	3-10-64
491718012	3/16	3-10-64
491718010	5/32	3-10-64
491718008	7/8	3-10-64
PART NO		BASE MATERIAL

ITEM NO.	REQ'D.	DESCRIPTION	DWG. OR CAT. NO.
		THROAT PLATE KNIFE CUTTING BAR IIIW17	PROJECT NUMBER
			THE SINGER COMPANY INDUSTRIAL PRODUCTS DIVISION MECHANIZED SYSTEMS DEPARTMENT
			DRAWING NUMBER
			491718
NAME		THROAT PLATE KNIFE CUTTING BAR IIIW17	
MATERIAL		DRAWN BY	N.C.
HEAT TREATMENT		DATE DRAWN	7-22-65
FINISH		SCALE	1:1
TOLERANCE UNLESS OTHERWISE SPECIFIED		DATE OF ISSUE	
DECIMAL: 2 PLACES ± .010 3 PLACES ± .005	FRACTIONS: ± 1/64	ANGLE: ±	ALL EDGES DROKEN .005 - .010

85-113

CHECKED BY
W.F.C.
1/1

491727

REVISIONS

SYM.	DESCRIPTION	CHG'D BY	CHG'D NO.	DATE
------	-------------	----------	-----------	------

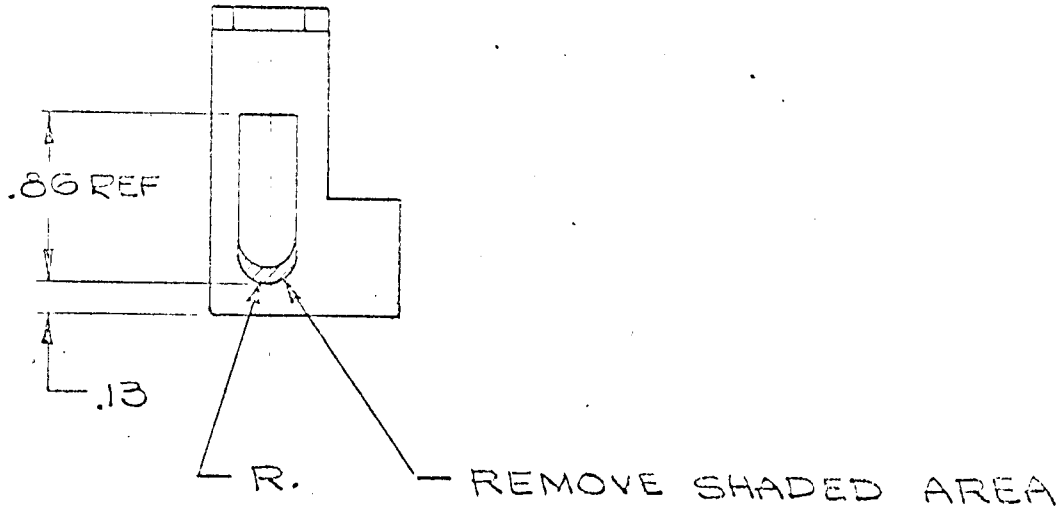

From the library of: Diamond Needle Corp

491727004	7-22-65	W.F.C.
491727015	7-22-65	W.F.C.
491727016	7-22-65	W.F.C.
491727012	7-22-65	W.F.C.
491727008	7-22-65	W.F.C.
PART NO		

ITEM NO.	REQ'D.	DESCRIPTION	DWG. OR CAT. NO.
----------	--------	-------------	------------------

NAME	LIFTING PRESSER FOOT , IIIW117				
MATERIAL	SEE CHART				
HEAT TREATMENT		DRAWN BY	N.C.	CHECKED BY	W.F.C.
FINISH		DATE DRAWN	7-22-65	ENG. APPR.	W.F.C.
USED ON		SCALE	1:1	MFG. APPR.	

PROJECT NUMBER
THE SINGER COMPANY
 INDUSTRIAL PRODUCTS DIVISION
 MECHANIZED SYSTEMS DEPARTMENT
 DRAWING NUMBER

TOLERANCE UNLESS OTHERWISE SPECIFIED	ALL EDGES BROKEN .005 - .010
DECIMAL: 2 PLACES ± .010 3 PLACES ± .005	FRACTIONS: ± 1/64 ANGLES: ±

DATE OF ISSUE

491727

492065-001

REVISIONS

SYM.	DESCRIPTION	CHG'D BY	CHK'D BY	DATE
C	REDRAWN WITH CHANGES	RML		
D	ADDED NOTE #1	RML		
E	REMD. DIMS. 28 DIA & .970	RML		

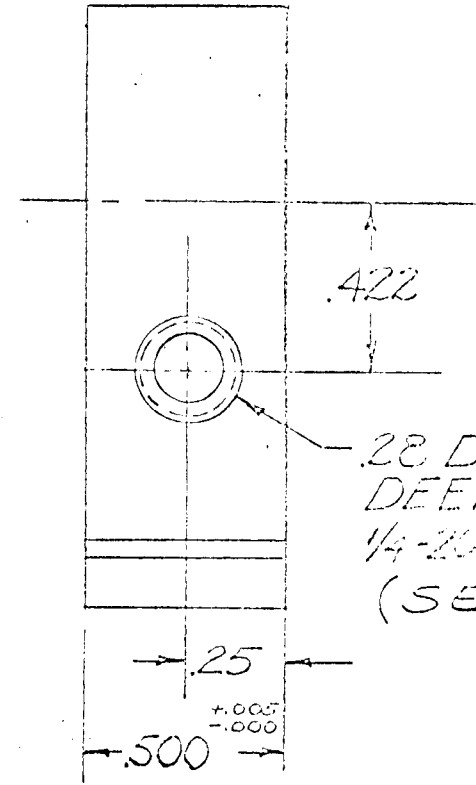
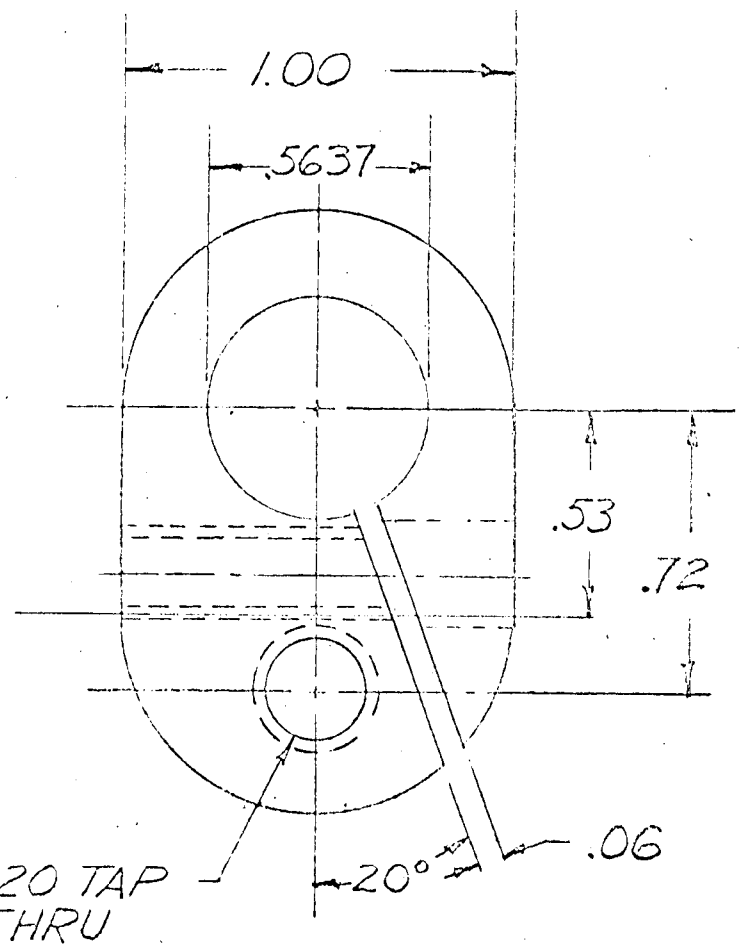

From the library of: Hamilton Needle Corp

5/16 -20 TAP THRU

28 DIA. C'BORE .25 DEEP. DRILL & TAP 1/4-20 THD THRU (SEE NOTE)

NOTE:
 1- ASSEMBLE SCREW, FIL. HD. #1/4-20 x 1" LG.
 2) BEFORE STOCKING PART

OLD NO MSD 1554

ITEM NO.	REQ'D.	DESCRIPTION	DWG. OR CAT. NO.
		FEED DRIVING ROCK SHAFT CRANK	PROJECT NUMBER
		MATERIAL: STEEL	THE SINGER COMPANY
		HEAT TREATMENT	INDUSTRIAL PRODUCTS DIVISION
385-113		FINISH: BLACK OXIDE	MECHANIZED SYSTEMS DEPARTMENT
		TOLERANCE UNLESS OTHERWISE SPECIFIED	DRAWING NUMBER
		DECIMAL: 2 PLACES ± .010	492065-001
		3 PLACES ± .005	
		FRACTIONS: ± 1/64	
		ANGLES: ±	
		ALL EDGES BROKEN .005 - .010	
		DATE OF ISSUE	

REVISIONS

SYM.	DESCRIPTION	CHG'D BY	CHK'D BY	DATE
------	-------------	----------	----------	------

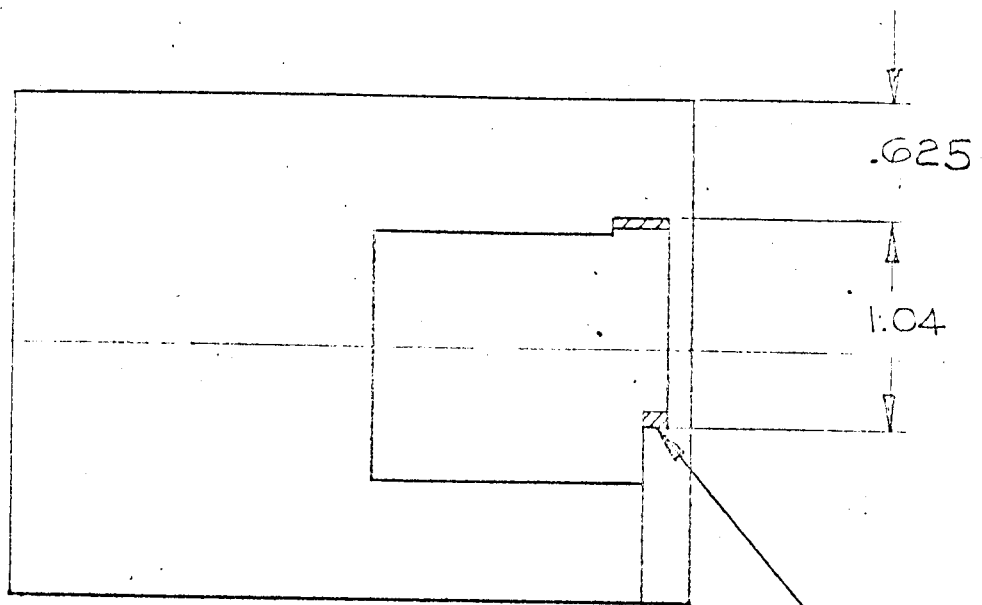

REMOVE SHADED AREA

From the library of: Diamond Needle Corp

ITEM NO.	REQ'D.	DESCRIPTION	DWG. OR CAT. NO.
		THROAT PLATE BODY IIIW117	
		MATERIAL 240401	PROJECT NUMBER
		HEAT TREATMENT	THE SINGER COMPANY INDUSTRIAL PRODUCTS DIVISION MECHANIZED SYSTEMS DEPARTMENT
25-112		FINISH	DRAWING NUMBER
		SCALE 1:1	422005-002
TOLERANCE UNLESS OTHERWISE SPECIFIED		DATE OF ISSUE	
DECIMAL: 2 PLACES ± .010 3 PLACES ± .005	FRACTIONS: ± 1/64	ANGLES: ±	
		ALL EDGES BROKEN .005 - .010	

REVISIONS

SYM.	DESCRIPTION	CHG'D BY	CHG'D BY	DATE
A	REDRAWN WITH CHANGES FOR SINGER			
B	ADDED NOTE #1	DTC		7/23/69

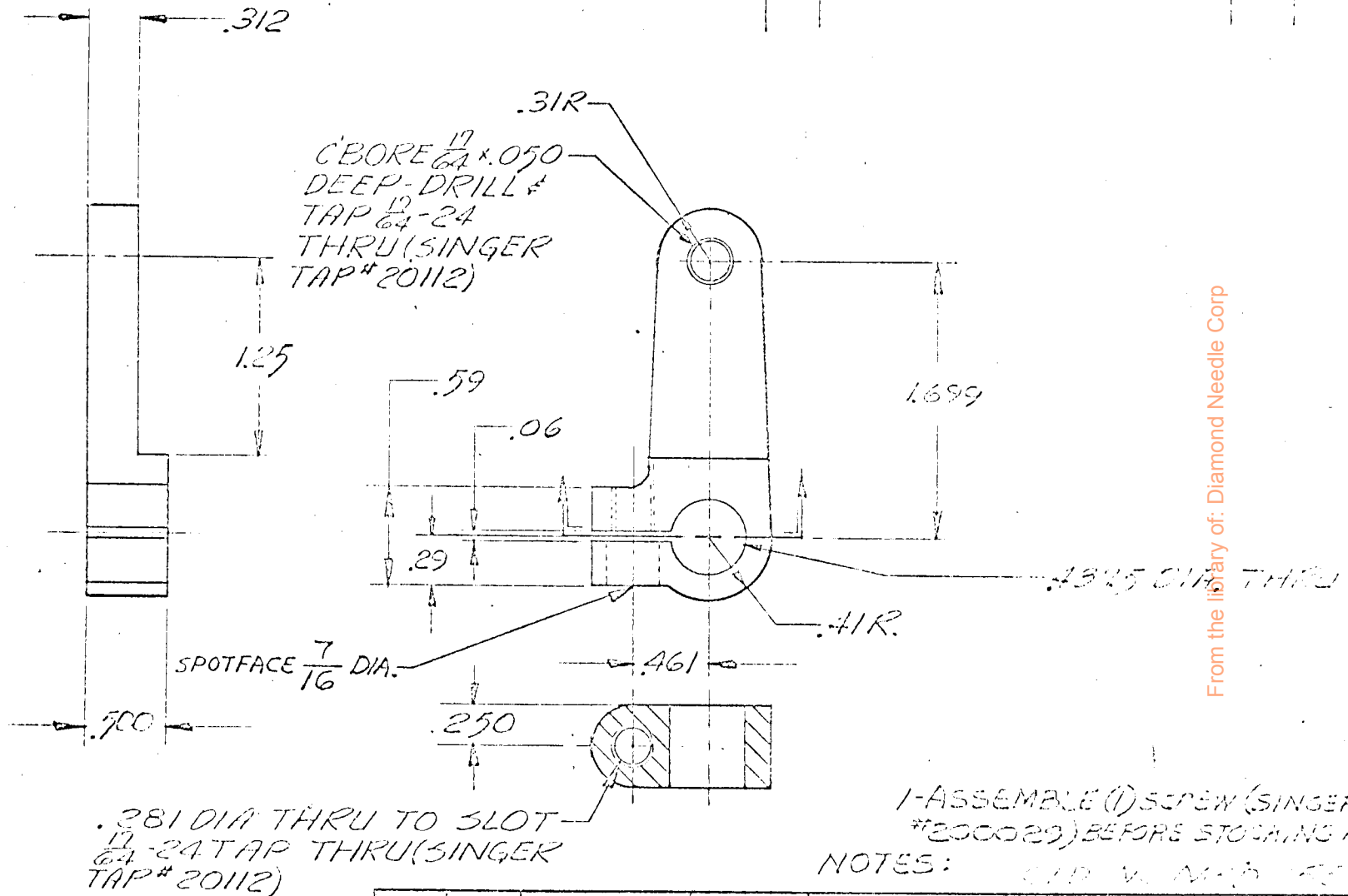

From the library of: Diamond Needle Corp

ITEM NO.	REQ'D.	DESCRIPTION	DWG. OR CAT. NO.
----------	--------	-------------	------------------

NAME	NEEDLE BAR ROCK FRAME ROCK SHAFT CRANK, IIIW117		
MATERIAL	STEEL		
HEAT TREATMENT			
FINISH	BLACK OXIDE		

PROJECT NUMBER	
THE SINGER COMPANY INDUSTRIAL PRODUCTS DIVISION MECHANIZED SYSTEMS DEPARTMENT	
DRAWING NUMBER	

TOLERANCE UNLESS OTHERWISE SPECIFIED			
DECIMAL: 2 PLACES ± .010 3 PLACES ± .005	FRACTIONS: ± 1/64	ANGLES: ±	ALL EDGES BROKEN .005 - .010
DATE OF ISSUE			

148065 003

885-113
USED ON

NOTES: (1) V. M. H. 117

REVISIONS

SYM.	DESCRIPTION	CHK'D BY	CHK'D BY	DATE
A2	REDIMENSIONED; REMOVED .45" R. WAS 5/16" R. ADDED 2.75	NOM	W.F.C.	10/1/65

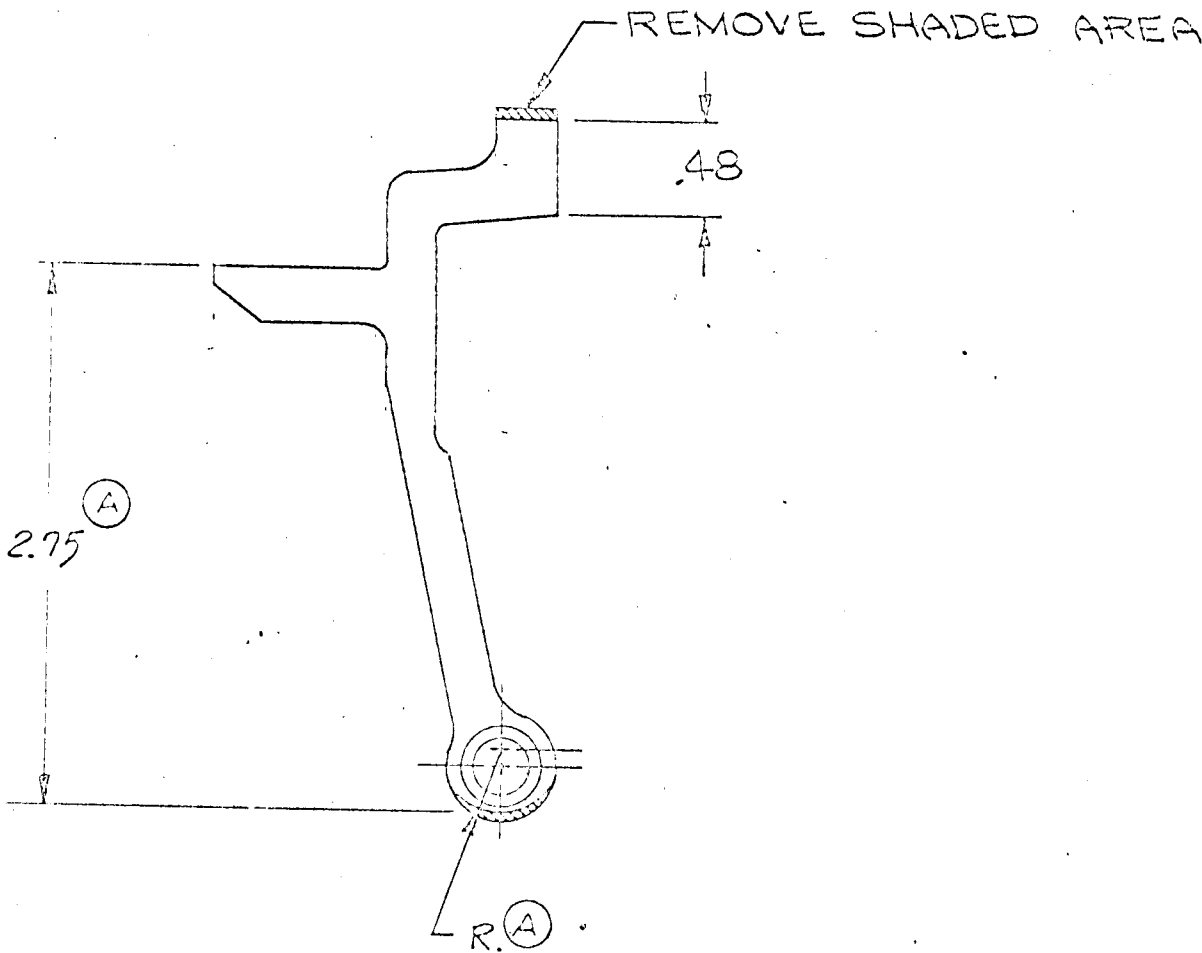

From the library of: Diamond Needle Corp

ITEM NO.	REQ'D.	DESCRIPTION	DWG. OR CAT. NO.
----------	--------	-------------	------------------

NAME	FEED BAR, IIIW117				PROJECT NUMBER	
MATERIAL	240454	DRAWN BY	W.F.C.	CHECKED BY	W.F.C.	THE SINGER COMPANY INDUSTRIAL PRODUCTS DIVISION MECHANIZED SYSTEMS DEPARTMENT
HEAT TREATMENT		DATE DRAWN	7-23-65	ENG. APPR.		
FINISH		SCALE	1:1	MFG. APPR.		
TOLERANCE UNLESS OTHERWISE SPECIFIED						

ALL: 2 PLACES ± .010 3 PLACES ± .005	FRACTIONS: ± 1/64	ANGLES: ±	ALL EDGES BROKEN .005 - .010	DATE OF ISSUE	10/1/65	DRAWING NUMBER
---	-------------------	-----------	---------------------------------	---------------	---------	----------------

132065 001

REVISIONS

SYM.	DESCRIPTION	CHG'D BY	CHK'D BY	DATE
A	REDIMENSIONED LOCATION OF SLOT: DELETED .455 DIM	NOMI	11.F.C.	10-25-67

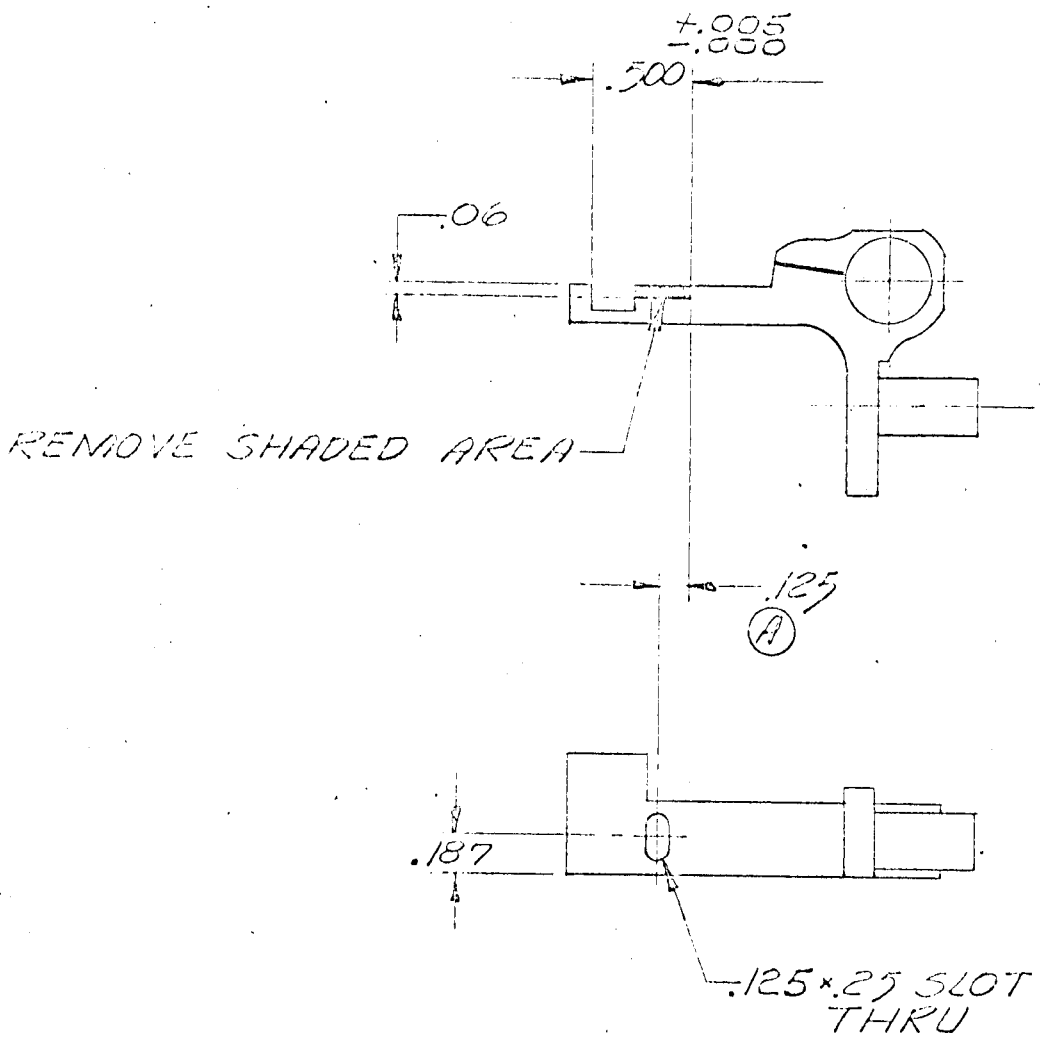

From the library of: Diamond Needle Corp

ITEM NO.	REQ'D.	DESCRIPTION	DWG OR CAT NO
----------	--------	-------------	---------------

NAME	PRESSER BAR LIFTING BRACKET			PROJECT NUMBER	
MATERIAL	264526			THE SINGER COMPANY INDUSTRIAL PRODUCTS DIVISION MECHANIZED SYSTEMS DEPARTMENT	
HEAT TREATMENT		DRAWN BY	NOMI	CHECKED BY	11.F.C.
FINISH		DATE DRAWN	10-25-67	ENG. APPR.	
USED ON		SCALE	1-1	MFG. APPR.	

TOLERANCE UNLESS OTHERWISE SPECIFIED			DATE OF ISSUE	4204-000
CIMAL: 2 PLACES ± .010 3 PLACES ± .005	FRACTIONS: ± 1/64	ANGLES: ±	ALL EDGES BROKEN .005 - .010	

REVISIONS

SYM.	DESCRIPTION	CHGD BY	CHK'D BY	DATE
A	ADDED NOTE #1	W.F.C.		

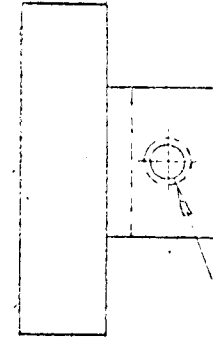
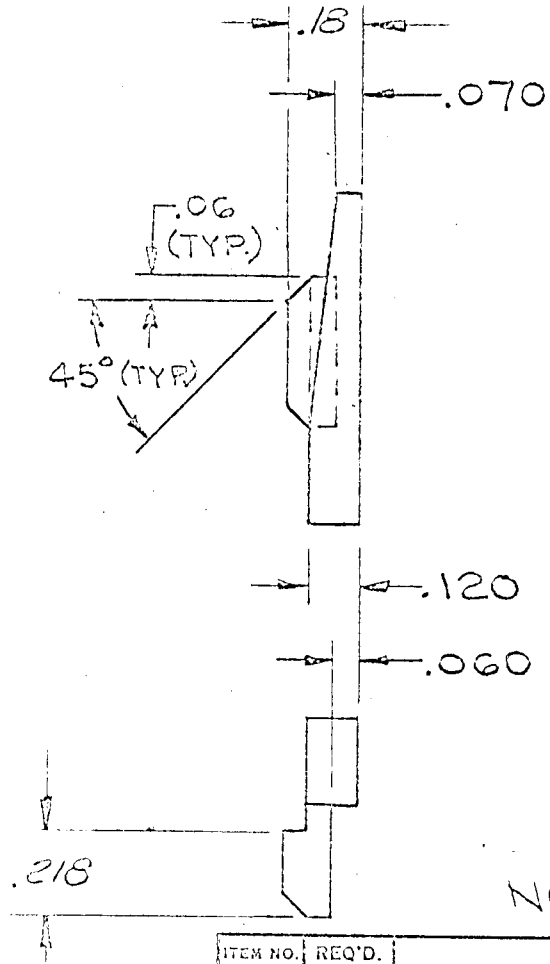
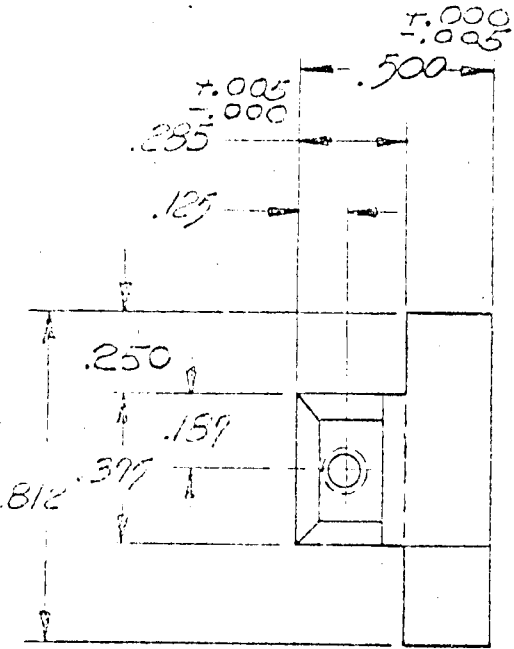

From the library of: Diamond Needle Corp

1- ASSEMBLE (1) SCREW, CAP, HEX. SKT. #4-40x1/4 LG. BEFORE STOCKING PART.

NOTES:-

OLD NO. 4-11-13-1

ITEM NO.	REQ'D.	DESCRIPTION	DWG. OR CAT. NO.
		ACTUATOR FINGER INSERT (IIIW117)	
NAME		ACTUATOR FINGER INSERT (IIIW117)	PROJECT NUMBER
MATERIAL		STEEL	THE SINGER COMPANY INDUSTRIAL PRODUCTS DIVISION MECHANIZED SYSTEMS DEPARTMENT
HEAT TREATMENT			
FINISH		BLACK OXIDE	
DRAWN BY		NOMI	DRAWING NUMBER
DATE DRAWN		10-20-67	
CHECKED BY		W.F.C.	4-22-67-10-11
ENG. APPR.			
SCALE		2-1	
DATE OF ISSUE		NOV 27 1968	
TOLERANCE UNLESS OTHERWISE SPECIFIED			
DECIMAL: 2 PLACES ± .010	FRACTIONS: ± 1/64	ANGLED: ±	
3 PLACES ± .005		ALL EDGES BROKEN .005 - .010	

REVISIONS

SYM.	DESCRIPTION	CHK'D BY	CHK'D DATE
------	-------------	----------	------------

REMOVE SHADED AREA

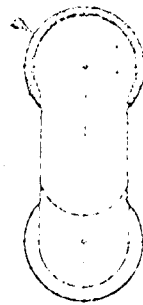
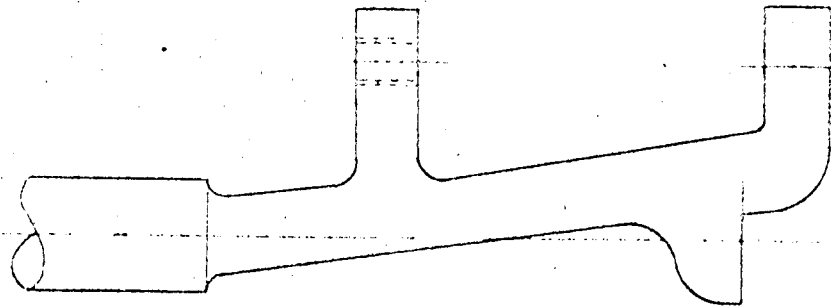

From the library of: Diamond Needle Corp

ITEM NO.		REQ'D.	DESCRIPTION			DWG. OR CAT. NO.
NAME		FEED DRIVING ROCK SHAFT			PROJECT NUMBER	
MATERIAL		223 650			THE SINGER COMPANY INDUSTRIAL PRODUCTS DIVISION MECHANIZED SYSTEMS DEPARTMENT	
HEAT TREATMENT					DRAWING NUMBER	
FINISH					4920657-000	
USED ON		SCALE 1-1			DATE OF ISSUE	
35-113		DRAWN BY NOMI			3/1/59	
		CHECKED BY J.M.F.C.				
		DATE DRAWN			ENG. APPR.	
		SCALE			MFG. APPR.	
		TOLERANCE UNLESS OTHERWISE SPECIFIED				
DIMALS: 2 PLACES ± .010		FRACTIONS: ± 1/64		ANGLES: ±		
3 PLACES ± .005		ALL EDGES BROKEN		.005 - .010		